

# Autodesk *Skill Builders*

A Skill-building Exercise

## The Measure Tool

### In This Exercise

The Measure tool is a versatile and convenient tool that you can use to quickly extract various kinds of measures from components within the part, assembly, and drawing environments.

This exercise provides illustrated guidelines to help you become comfortable with using the Measure tool in the part environment.

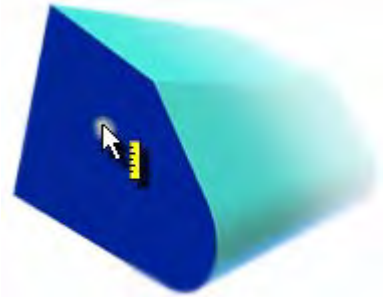

### Build a Simple Example Model

Create a part using the metric Standard.ipt template. Reproduce the sketch profile, dimensions, extrusion and round shown in the following illustration.

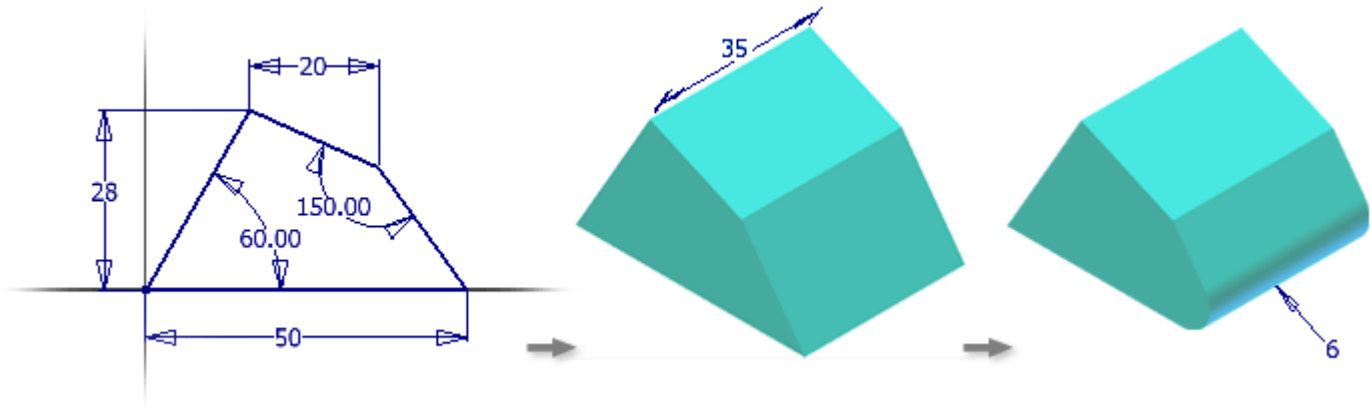

Select Tools > Document Settings from the main toolbar. On the Units tab, set Linear Dim Display Precision to **0.12**.

Click the Rotate tool and position the model to approximate the view angle shown in the left portion of the illustration. While the Rotate tool is still active, press the spacebar to activate the Common View tool. Select the direction arrow to set the isometric view. Right-click, and then select Redefine Isometric. Press Esc. You can save the part, if desired.

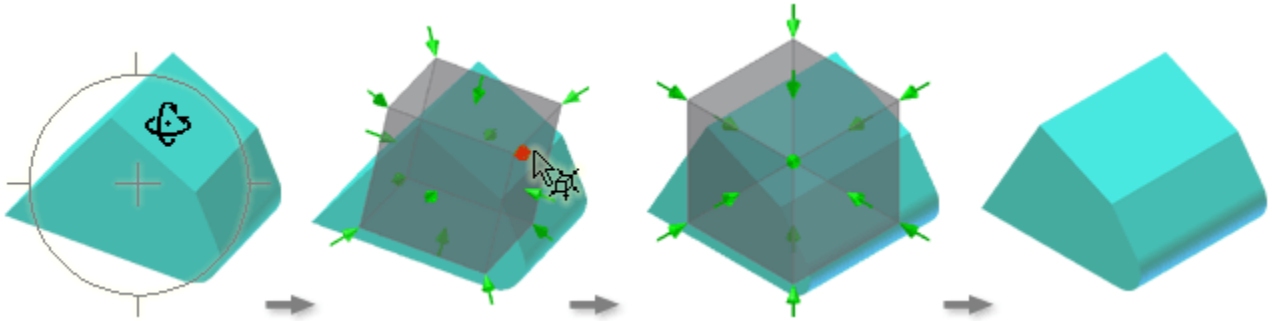

## Measure Distance

1. From the main toolbar, select Tools > Measure Distance. Select the edge, as shown. Notice the distance 21.9 mm is returned in the Measure Distance dialog box.

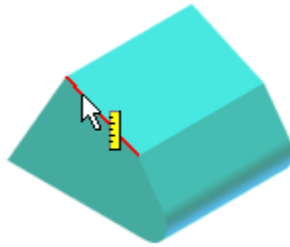

Select the pull-down arrow in the Measure Distance dialog box, and then select Restart to reset the measure tool.

Select the edge of the round. Notice the radial distance of 6 mm is returned.

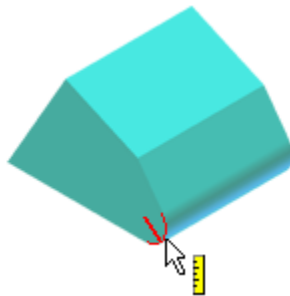

Reset the Measure tool. Select the edge, and then select the edge of the round, as shown. Notice that the linear distance 30.11 mm (the distance from the edge to the center point of the round) is returned.

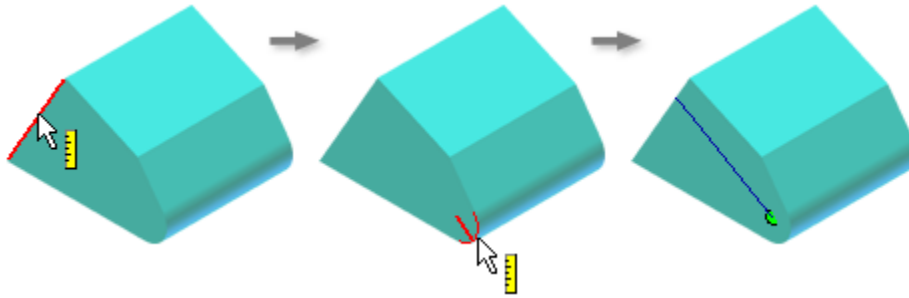

Reset the Measure tool. Expand the Origin folder in the browser. Select the Z axis, and then pause over the face of the round until its axis is displayed. Select the round. A distance of 38.7 mm is returned.

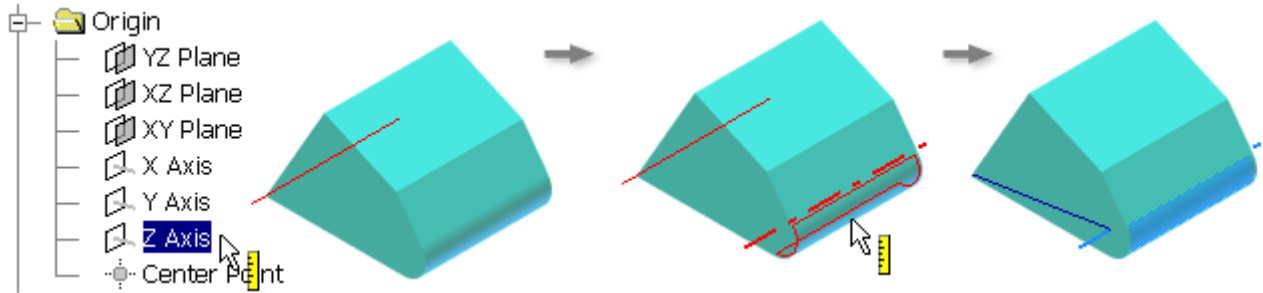

## Measure Angle

Select the pull-down arrow in the dialog box, and then select Measure Angle. Select the two faces, as shown.

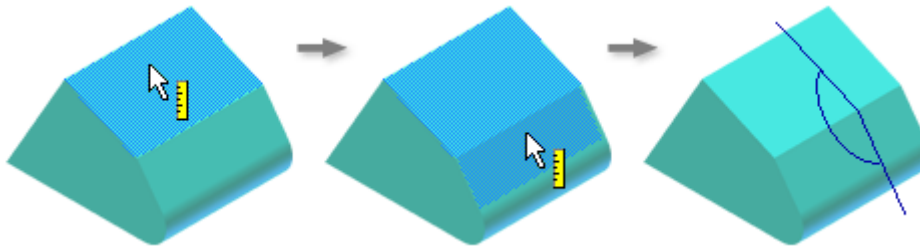

Reset the Measure tool. In the Origin folder, select the Y axis, and then select the plane on the model, as shown.

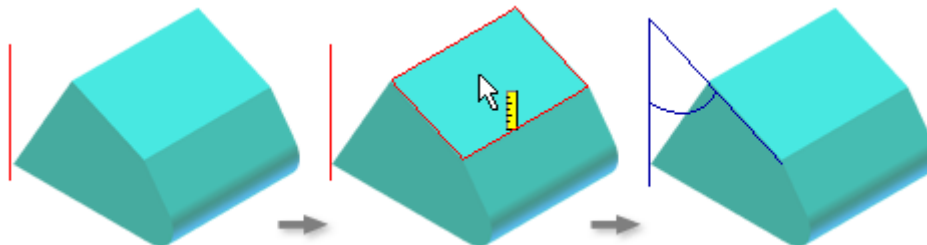

## Measure Loop

Select the pull-down arrow in the dialog box, and then select Measure Loop. Select the face, as shown.

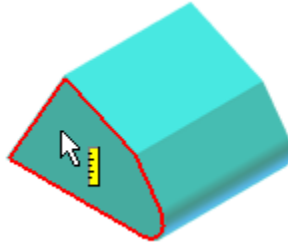

Reset the Measure tool. Select the face of the round.

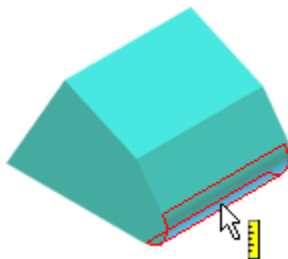

## Measure Area

Select the pull-down arrow in the dialog box, and then select Measure Area. Select the face, as shown.

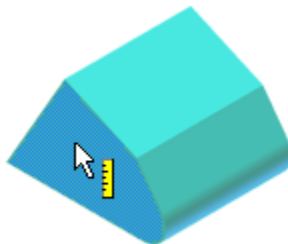

Reset the Measure tool. Select the face of the round.

## The Add to Accumulate Function - Summing Measure Figures

Select the pull-down arrow in the dialog box, and then select Measure Distance. Select the edge, as shown in the following illustration.

Select the pull-down arrow in the dialog box, and then select Add to Accumulate.

Select the vertex, and then select Add to Accumulate once again.

Select the pull-down arrow in the dialog box, and then select Display Accumulate. The sum of the length of the edge and the distance from the edge to the vertex is displayed.

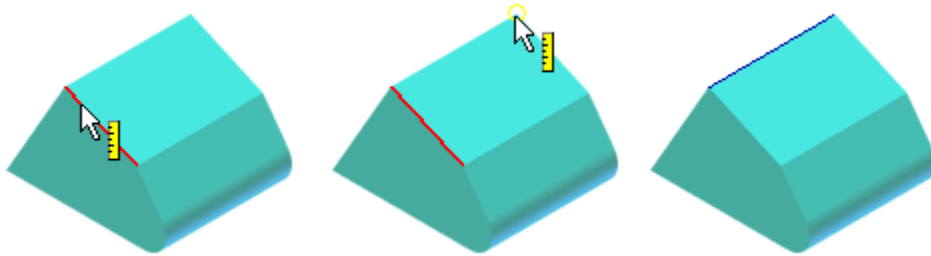

Let's take a look at how the Measure tool sums measures.

Selecting Add to Accumulate is like pressing the **+** key on a calculator. Selecting Display Accumulate is like pressing the **=** key on a calculator. However, unlike the basic sum sequence on a calculator, you must explicitly specify the accumulation of each number in a sequence. For example, if you want to add **2 + 2** with a calculator, there is no need to press **2 + 2 + =**. You simply press **2 + 2 =**. The calculator understands that the two numbers are part of an accumulation. The Measure tool requires that you specify each measure to sum by selecting Add to Accumulate after each measure. By analogy, to sum measures with the Measure tool, you do need to press **2 + 2 + =**. This may indeed seem counter-intuitive or unnecessary. In fact, it builds flexibility in the measure process.

Because each measure must be explicitly specified to accumulate as part of a sum, you can also exclude any measure from a summing sequence by not choosing Add to Accumulate after that particular measure. In other words, you're free to take that measurement without disturbing an accumulation sequence, taking a detour, as it were, from the accumulation sequence. Add to Accumulate serves as an independent storehouse of figures. As you work your way through a measure sequence, you decide which figures to include in that storehouse and which to exclude. Selecting Add to Accumulate is like pressing the **M+** (add to memory) key on a calculator. Selecting Display Accumulate is like pressing the **RM** (recall memory) and **=** keys.

**Note:** The Add to Accumulate function stores figures only until you specify Clear Accumulate or close the Measure dialog box. The data do not persist beyond one of those two actions. However, selecting Restart in the Measure dialog box clears the current selection set, but does not erase any accumulation.

## Add to Accumulate Exercise

You may find it helpful to work through the following exercise to become more comfortable with this function.

Select Tools > Measure Angle on the main toolbar.

Select the first face. Select the second face.

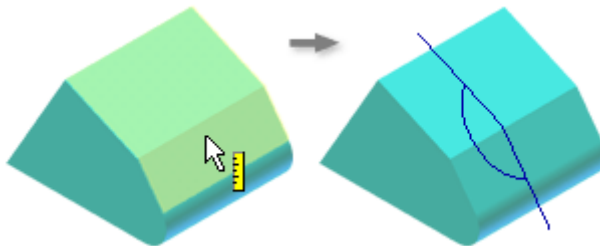

Notice the angle of 150 degrees is returned.

Select the pull-down arrow in the dialog box, and then select Add to Accumulate.

The figure 150 is added to the Add to Accumulate storehouse and you're ready to make the next selections.

Select the next two faces, as shown.

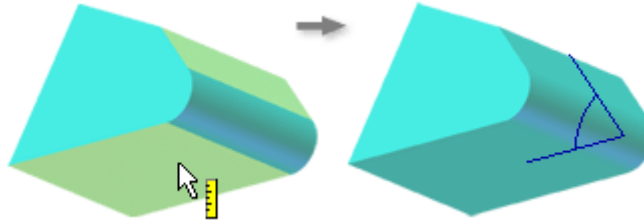

**Tip:** You can use the Rotate tool or the Select Other tool to gain access to the hidden faces.

Select Add to Accumulate.

Select the next two faces.

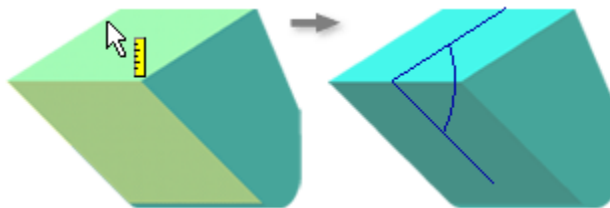

Select Add to Accumulate.

Select the next two faces.

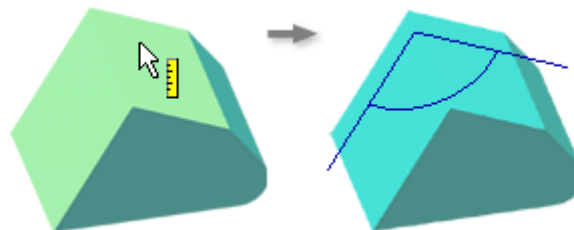

Select Add to Accumulate.

Select Display Accumulate.

Because we included each angle around the "perimeter" of the part in this accumulation, the total is 360 degrees.

Select the pull-down arrow in the dialog box, and then select Clear Accumulate.

Now let's check an angle in the midst of creating an accumulation without adding that angle to the accumulation.

Select the first two faces just as you did at the beginning of the preceding exercise.

Select Add to Accumulate.

Select the next two faces.

Select Add to Accumulate.

Select the next two faces.

This time **do not** select Add to Accumulate.

Select the next two faces.

Select Add to Accumulate.

Select Display Accumulate. Because we did not include the 60 angle in the sequence, the sum 300 degrees is returned. In other words, we were free to check the 60 angle without disrupting or interrupting the Add to Accumulate sequence.

## Understanding Distance, Position, and Delta

Create a part using the metric Standard.ipt template. Use the following illustrations as a guide.

Sketch the profile, matching the dimensions.

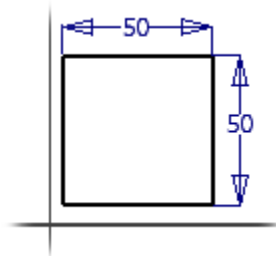

Project the origin Center Point into the sketch, and then use the Coincident constraint tool to constrain the lower left point of the sketch profile to the center point. This will ensure that this point of the sketch profile is positively located at sketch coordinates 0,0.

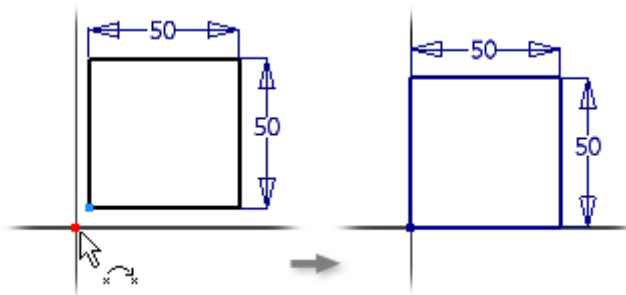

Extrude the profile to 50 mm.

**Important:** Ensure that you select the middle button for the extrusion direction in the Extrude dialog box to flip the extrusion direction.

Right-click, and select Isometric View.

Activate the Measure Distance tool, and then select the vertex, as shown.

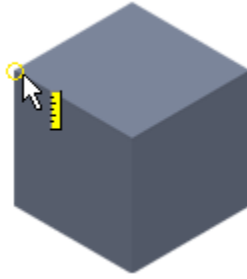

Because this vertex corresponds with the point in the sketch that we constrained to sketch coordinates 0,0, the X and Y positions for this vertex are also 0,0. The Z position is 0 because the vertex lies on the sketch plane of the base extrusion.

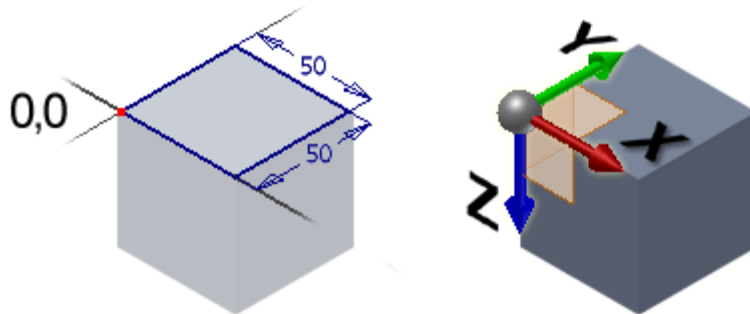

Select the next vertex, as shown.

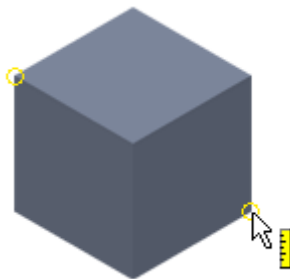

We now have three kinds of data displayed in the Measure dialog: distance, position, and delta.

The distance from the first vertex to the second vertex is 86.60 mm.

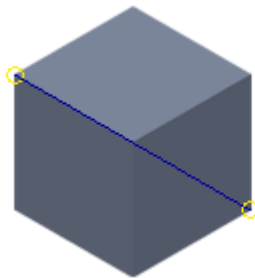

The X and Y positions of this second vertex are both 50 mm from base sketch coordinates 0,0. The Z position is -50 mm from 0,0. Position is always direction-specific, that is, the value can be either positive or negative.

The delta is 50 mm for each direction. The delta is relative to the preceding selection (the first vertex) not the base sketch 0,0.

Add a second extrusion to the first extrusion. Use the top of the cube for the sketch plane (ensure that the cube is set to the default isometric view). Use the dimensions and extrusion direction, as shown.

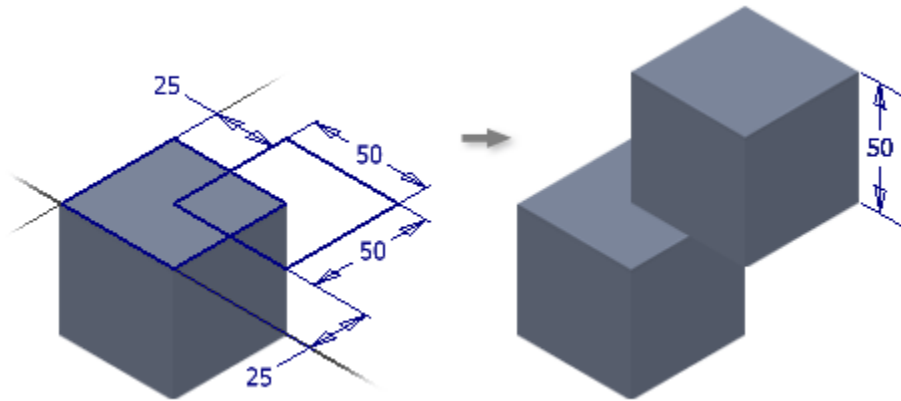

Select the first vertex. The X and Y positions are both 75 mm from the base sketch coordinates 0,0. The Z position is 50 mm from 0,0.

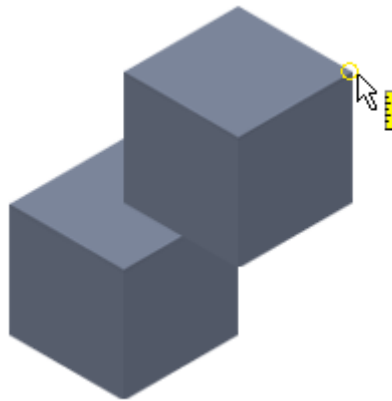

Select the next vertex. The distance is 127.48 mm from the preceding selection (the first vertex). The X position is 50, the Y position is 0, and the Z position is -50, each position relative to the base sketch 0,0 coordinates. The delta for the X position is 25 mm. The delta for Y is 75 mm. The delta for Z is 100 mm.

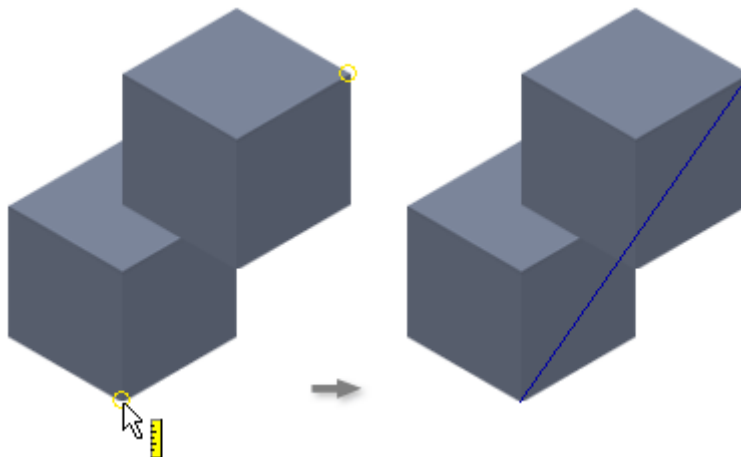

When you measure a distance using a vertex as a reference point, remember that the **distance** is always the linear measure between two selections, the **position** is always relative to the base sketch 0,0 coordinates and the base sketch plane, and the **delta** is always relative to the preceding selection.